

**Decrease in downtime.
Increase in output. Year after year!**



Bearing solutions for pulp and paper industry

WHO IS NBC



Founded in 1946, NBC is India's first bearings manufacturer and the last word in quality and durability. In 2020, the company acquired leading European manufacturer, Kinex Bearings to further boost its expertise.

75 years since its beginning, NBC remains India's leading bearings manufacturer and exporter. NBC is also the world's only bearings manufacturer to receive the prestigious Deming Grand Prize for Total Quality Management.

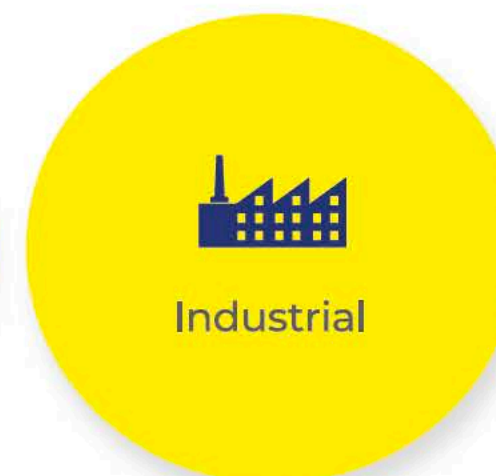
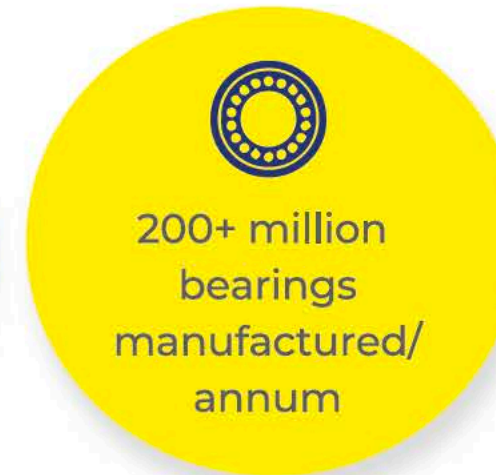

The environment inside the paper-making industry is very harsh for bearings to operate effectively. The dimensions of paper machines measure up to 200 meters in length, 20 meters in height, and 10 meters in width. The paper web that passes through these huge machines can be 2000 meters long, thereby putting a considerable load on the bearings, rollers, and cylinders.

Considering these machines operate day in and day out, all year round, a tremendous amount of strain on bearings can result in unplanned downtime. Especially in the case of the Paper Industry, the complex stages involved in the process and continuous nature of production reduce the life of bearings causing unexpected failure.

Significant challenges faced in the paper industry are mainly due to

- **Corrosive environment (primarily in Forming and Press section)**
- **Low load (Primarily in large size spherical bearings)**
- **High speed**
- **High temperature and rapid heating (primarily in the Dryer and Calender section)**
- **Paper scraps and debris**
- **Misalignment due to long and heavy roll sections**

Why is NBC Bearings important for the Paper & Pulp Industry



Over the last few years, the paper manufacturing industry has been focusing on increasing the speed and the width of the papermaking machines to enhance productivity. Therefore, reliable bearing is one of the most important parameters for the relentless functioning of papermaking machines.

NBC Bearings has developed a complete range of bearings that meets customers' objectives and can be used in all sections of a modern paper-making machine. We provide a wide product range and excellent choices that contribute to productivity enhancement.

Highly-engineered bearing solutions to reduce total cost of ownership



Bearings for optimal performance



Deep Groove Ball Bearing



Spherical Roller Bearing



Tapered Roller Bearing



Cylindrical Roller Bearing



Angular Contact Ball Bearing



Self-aligning Ball Bearing



Unit Bearing



Thrust Spherical Roller Bearing



Adapter Sleeve

NBC Solutions for different sections of Paper Making Machine

PULP MANUFACTURING

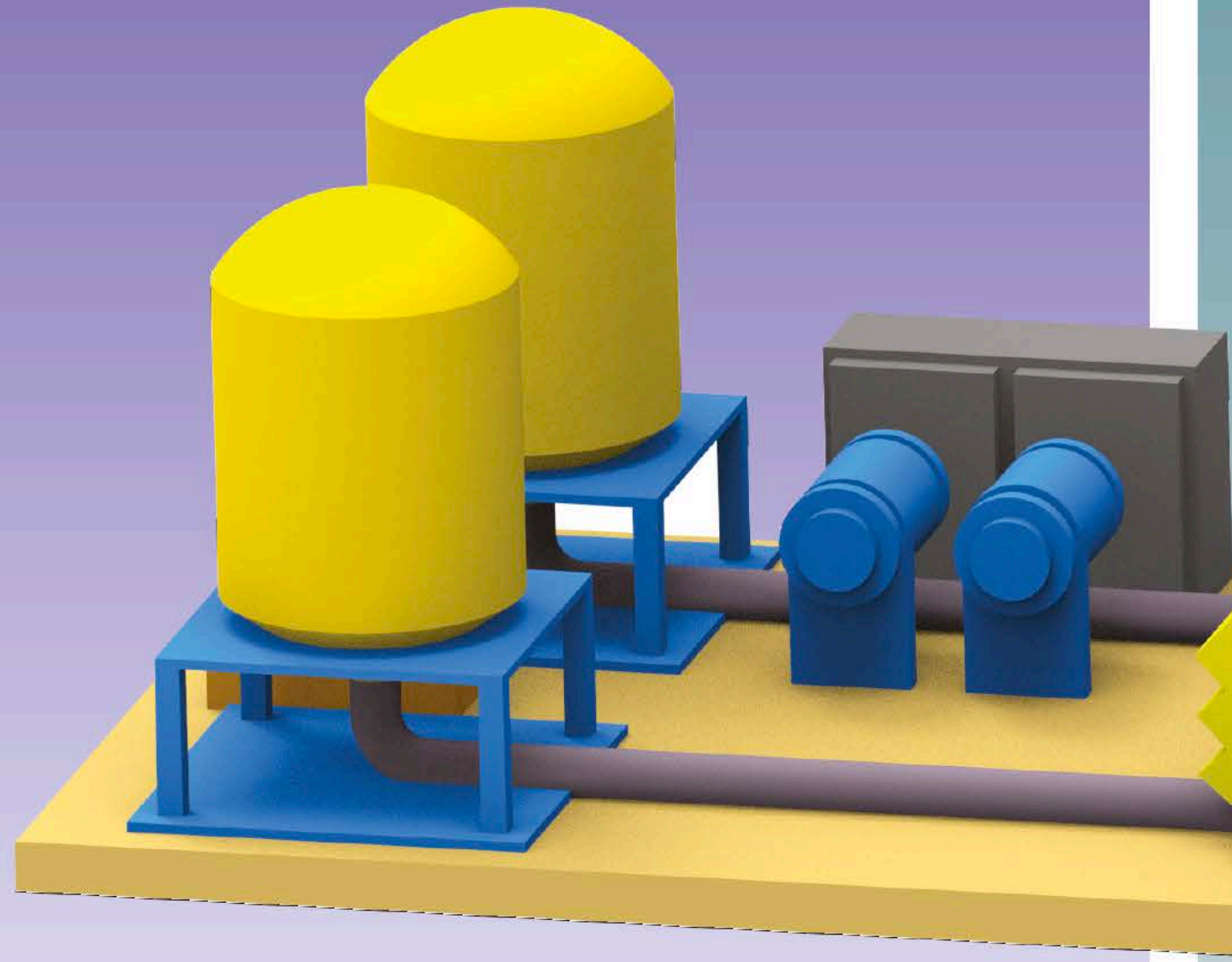

-  **Spherical Roller Bearing**
-  **Tapered Roller Bearing**
-  **Cylindrical Roller Bearing**
-  **Solid Lube Bearing**
-  **Thrust Spherical Roller Bearing**

FORMING SECTION

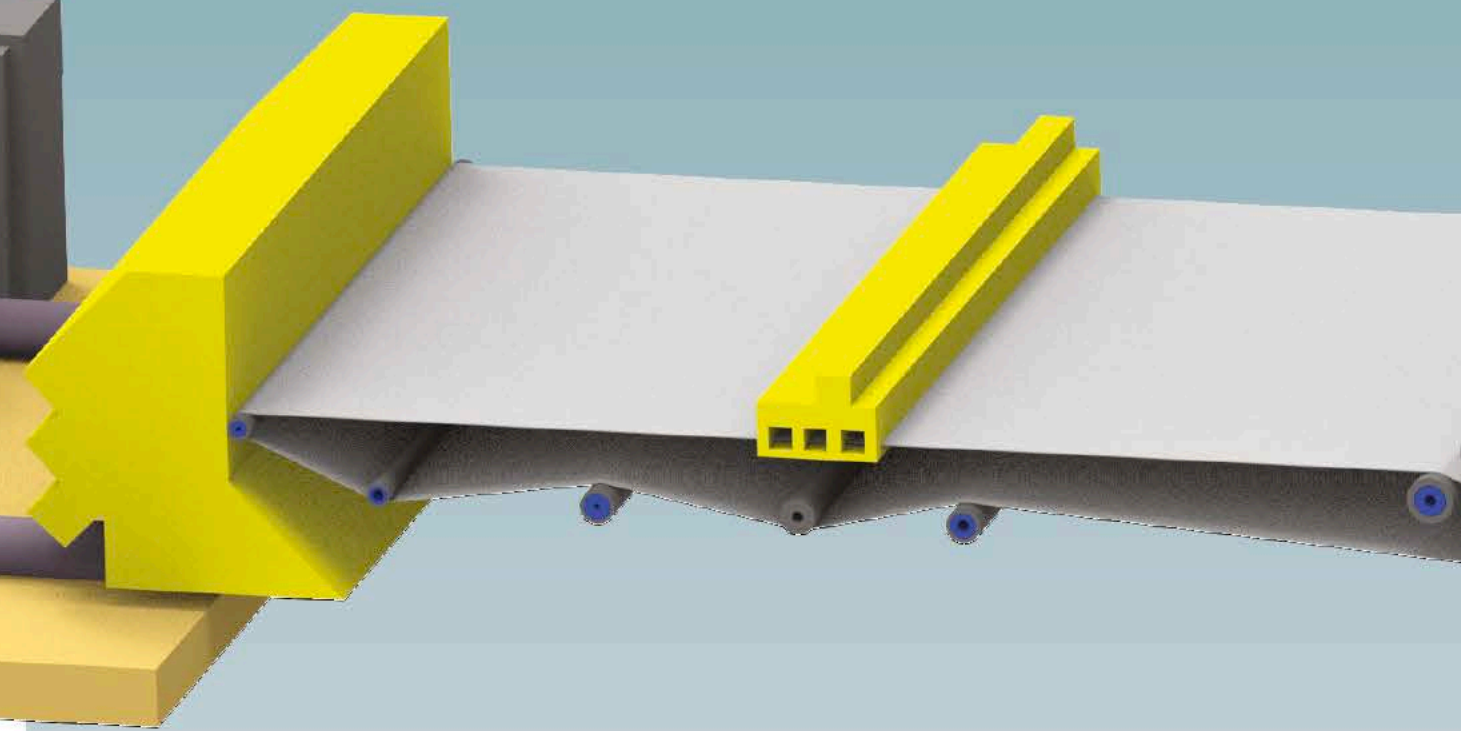

-  **Spherical Roller Bearing**
-  **Tapered Roller Bearing**
-  **Hybrid Ball Bearing**
-  **Solid Lube Bearing**
-  **HCP Coating
(Thin Dense Chrome)**

PRESS SECTION

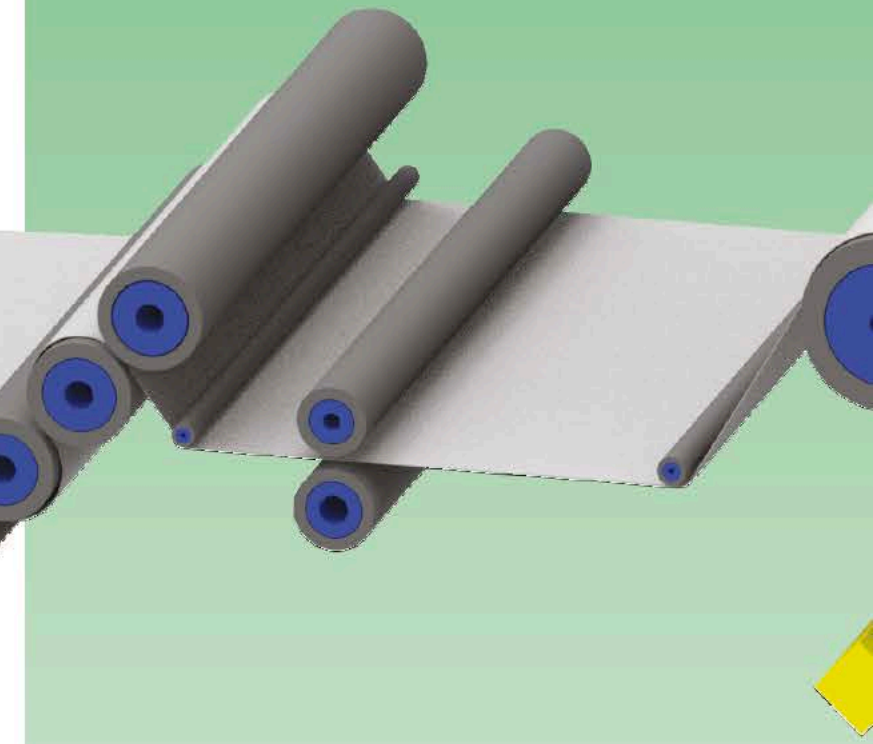

-  **Spherical Roller Bearing**
-  **Tapered Roller Bearing**
-  **HCP Coating
(Thin Dense Chrome)**
-  **HCR Coating
(Tungsten Carbide Coating)**

NBC Solutions for different sections of Paper Making Machine

DRYER SECTION

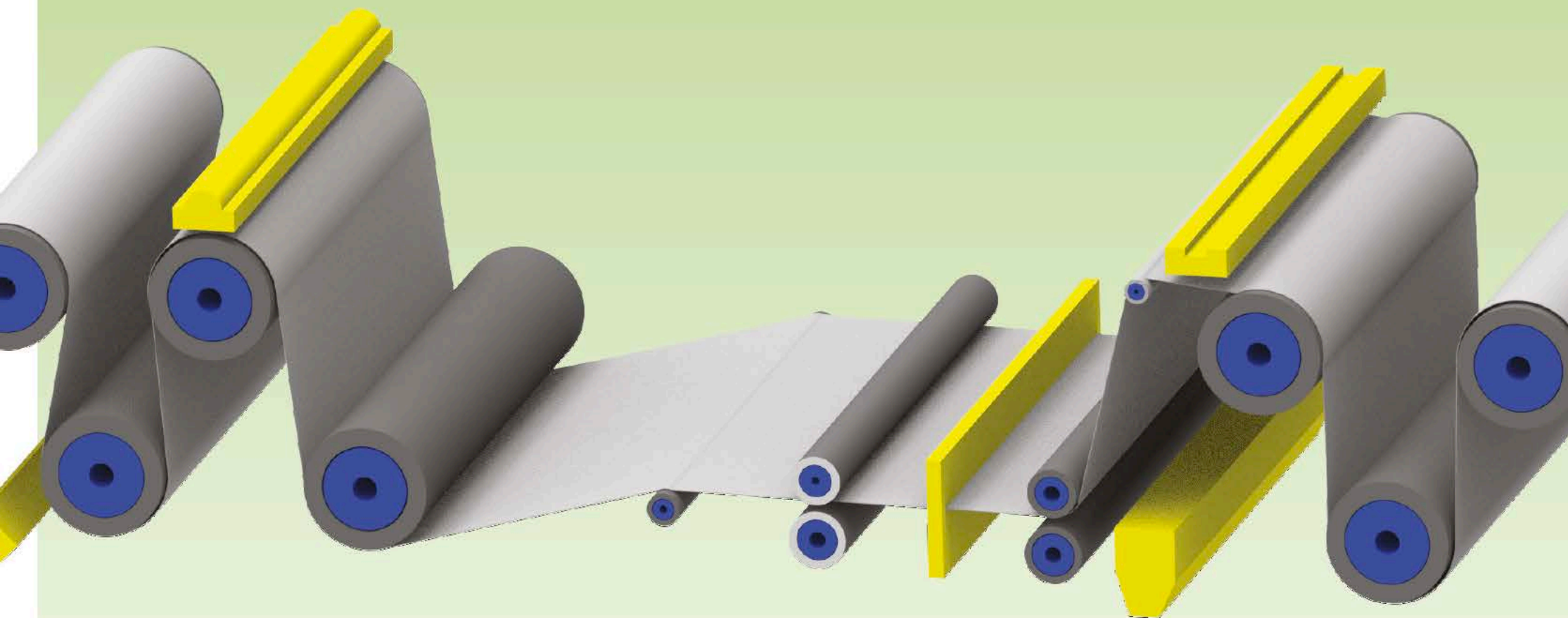

Spherical Roller Bearing



Case Carburized Bearing



**HCR Coating
(Tungsten Carbide Coating)**

CALENDER SECTION

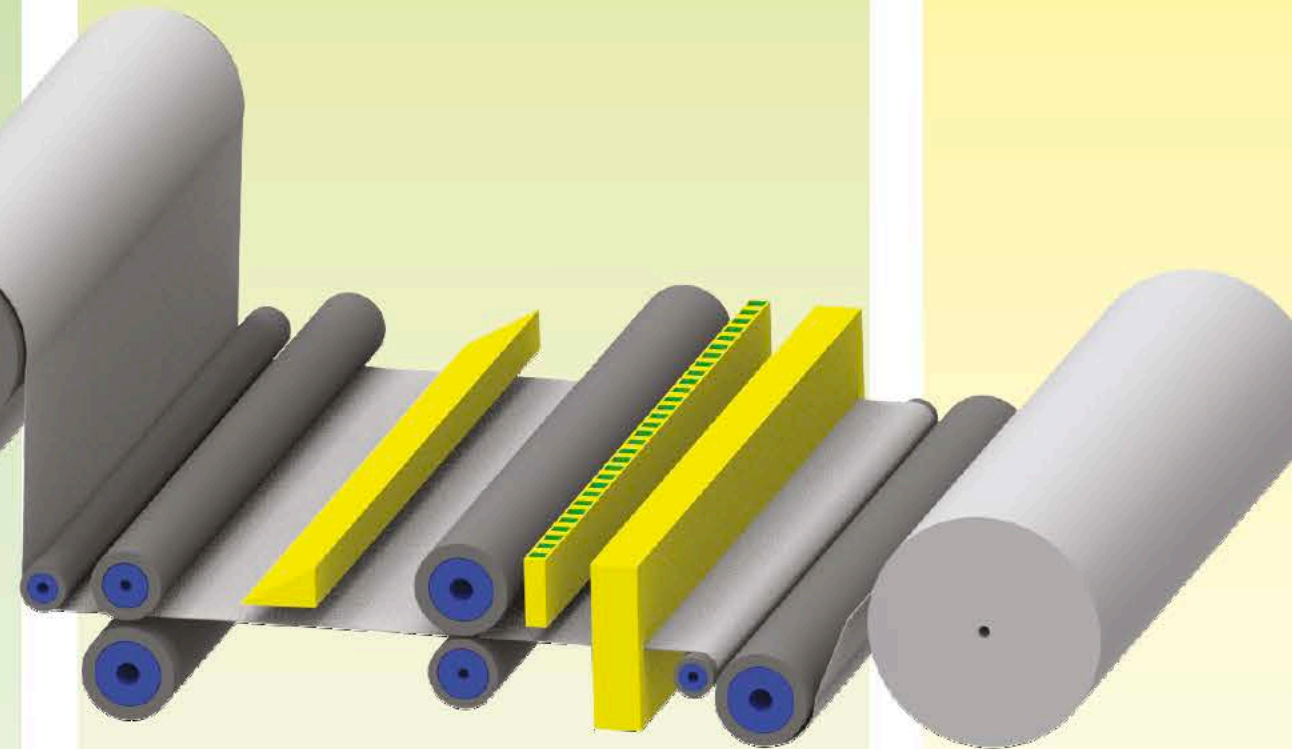

Spherical Roller Bearing



Two Row Tapered Roller Bearing



**HCR Coating
(Tungsten Carbide Coating)**



Case carburized Bearing

REEL SECTION

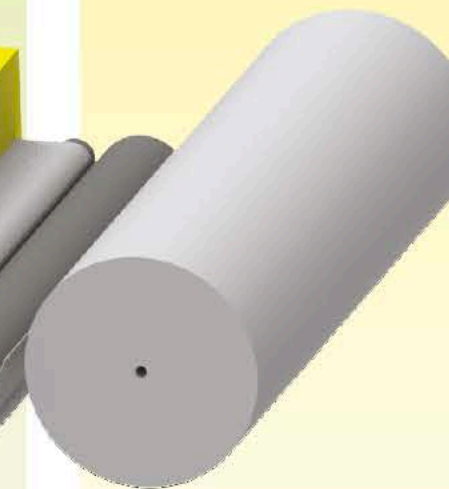

Spherical Roller Bearing



Tapered Roller Bearing

Major challenges faced by the paper industry and offered solutions

FORMING SECTION

The forming section, also called the wet end, is the first stage in paper-making machines and plays an essential role in achieving desired properties in the final paper product. It initiates the process by vacuuming out water from the suspension in a controlled way, producing a specific grade of paper.

Initially, the stock contains 99% water, and by the end of the forming section, the water content is reduced to 80%.

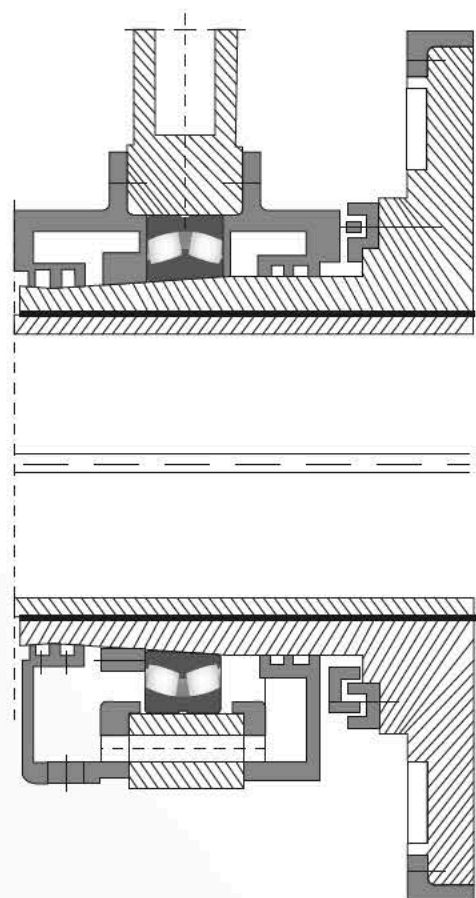

Key parts of forming sections

- Breast Roll
- Table Roll
- Dandy Roll
- Couch Rolls
- Wire Roll



CHALLENGES	SOLUTIONS
Corrosion due to highly wet environment (99% water)	HCP (Thin Dense Chrome) Coated Bearings for corrosion protection
Contamination	1) HCR (Tungsten Carbide) Coated Bearings for wear resistance 2) Sealed Spherical Roller Bearing with engineered rubber seals
Lubrication washout	Oil Impregnated Bearings having self-lubricating property
Smearing damage due to roller skidding (in high speed and low load condition)	HCR (Tungsten carbide) Coated Bearings for significantly reduced smearing damage
High-speed (Expander rolls)	Hybrid Ball Bearings for reduced frictional torque and lower centrifugal forces

PRESS SECTION

The Press section is the second section of the paper machine; it removes the remaining water through a system of nips formed by rolls pressing against each other. It comprises press felts supporting the sheet and absorbing the squeezed water.

The paper web consistency leaving the press section can be above 40%.

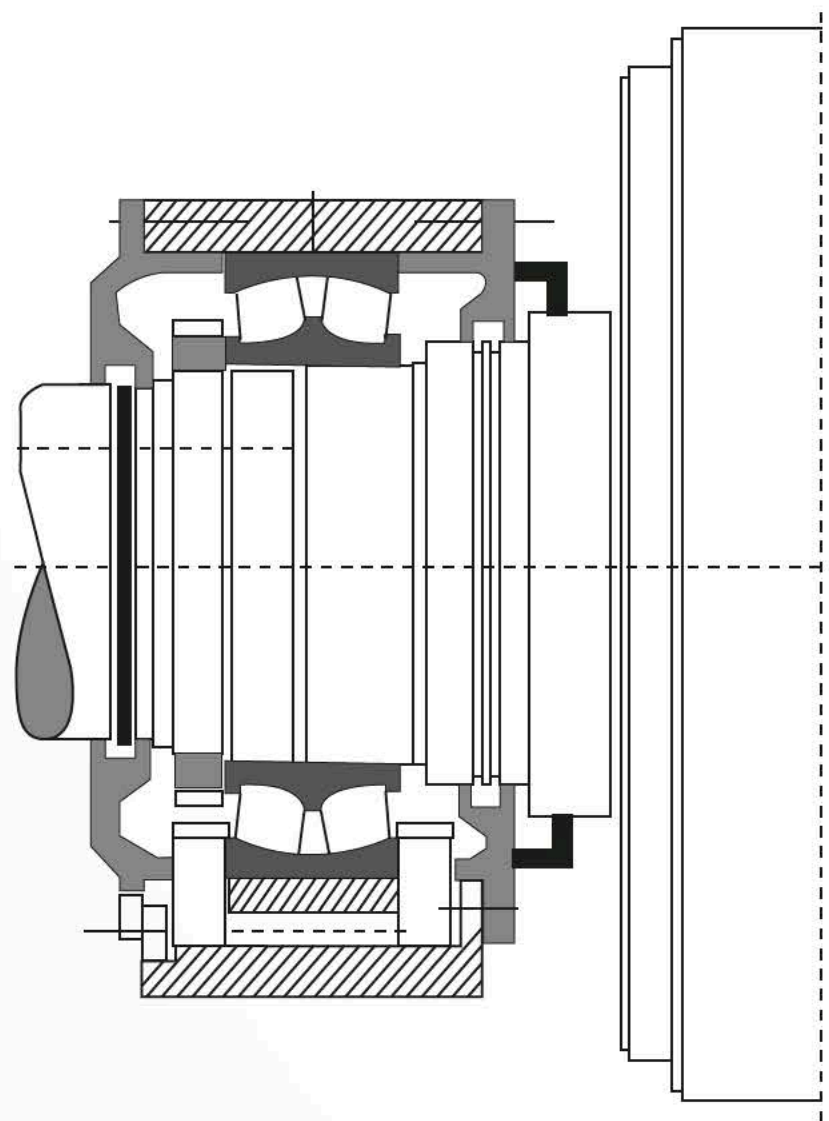

Key parts of press sections

- Suction Roll
- Press Roll
- Crown Control Roll
- Wet Felt Roll



CHALLENGES

SOLUTIONS

Corrosive environment

HCP (Thin Dense Chrome) Coated Bearings for corrosion protection

High misalignment

Optimized internal design Spherical Bearings to accommodate misalignment

Marginal lubrication

HCR Coated Bearings - Improved surface finish significantly enhances performance in marginal lubrication condition

DRYER SECTION

The next major process in a paper machine is Drying. The sheet formed in the forming section is unconsolidated and dewatered in the press section and enters the dryer section for further extraction of remaining water content. Finally, the separated mesh of fibers is combined into the dense and continuous network in the Drying section by moving its overheated drying cylinders.

After this section, the moisture content of the sheet is 5-10%.

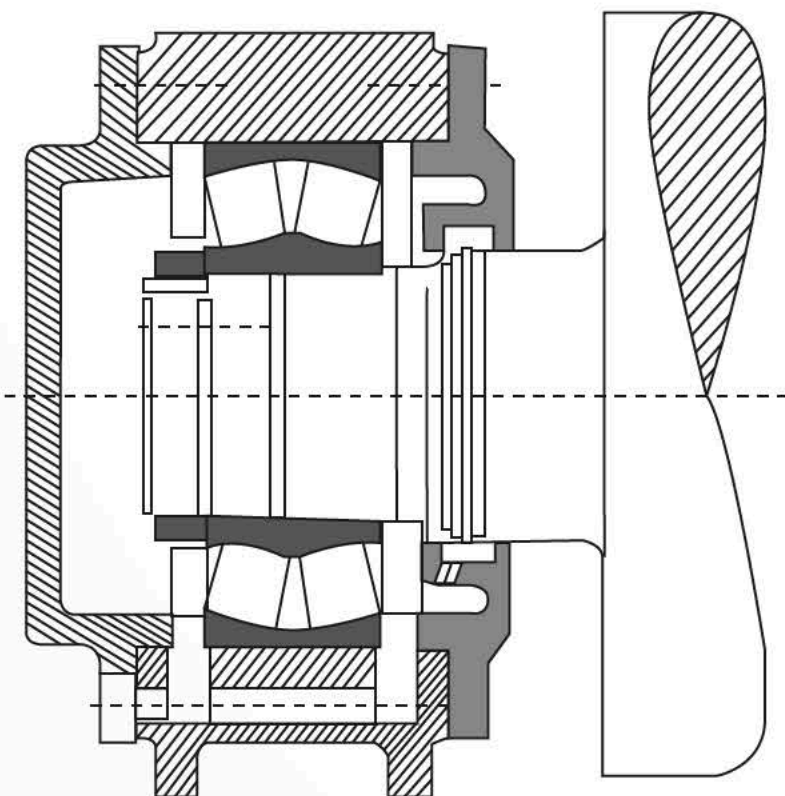

Key parts of drying sections

- Felt Roll
- Drying Cylinders
- Vacuum Roll
- Breaker Stack
- Size Presses
- Yankee Cylinders
- Rope Sheaves



CHALLENGES

SOLUTIONS

Inner ring fracture due to rapid heating

Case Hardened Inner Ring- Reduces risk of inner ring crack due to thermal stresses

High temperature

SRBs with C4 or custom clearance to compensate thermal expansion in bearing

Smearing damage due to roller skidding in high speed and light load

HCR (Tungsten carbide) Coated Bearings for significantly reduced smearing damage

CALENDER SECTION

A single continuous sheet is passed through the pairs of heated rolls known as calender rolls in the calender section. These rolls are made of steel with a hardened surface.

The function of the calender is to impart the finishing by smoothing and compressing the paper, thereby enhancing printing properties.

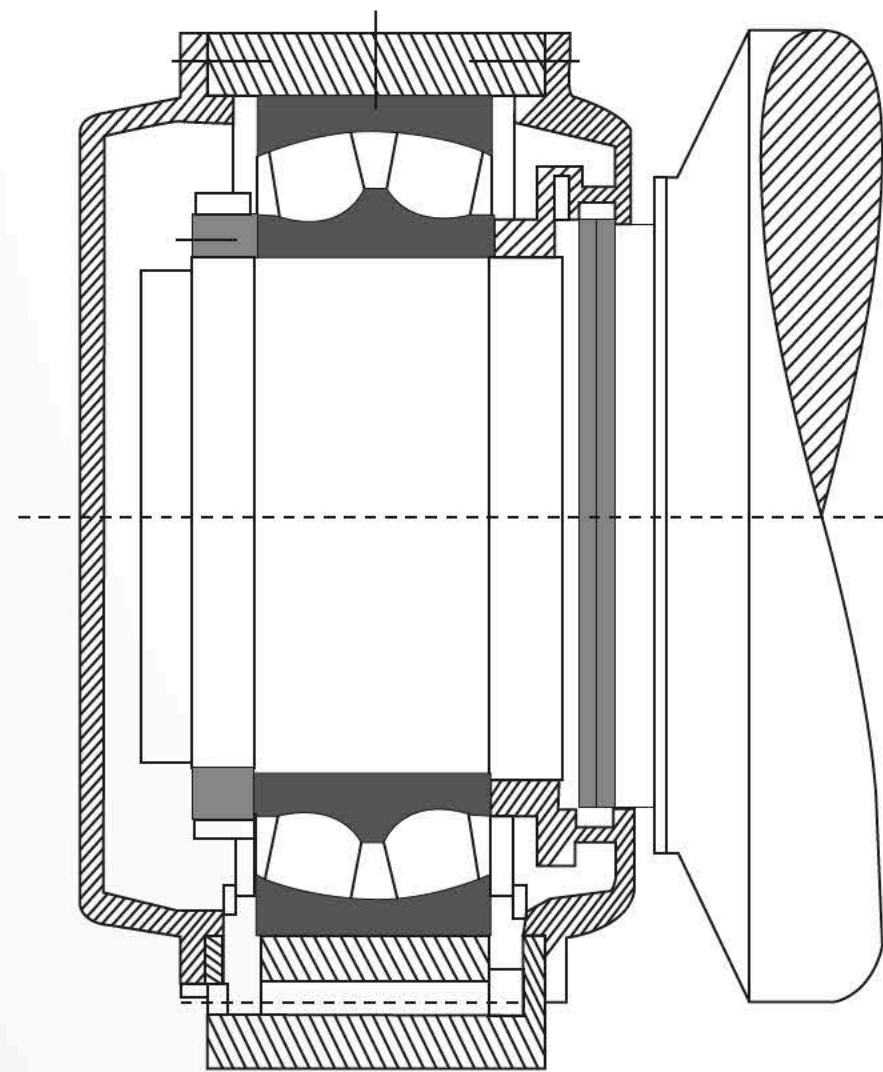

Key parts of calender sections

- Top Roll
- Intermediate Roll
- Queen Roll
- Deflection Roll
- Compensating Roll

CHALLENGES	SOLUTIONS
Ring cracking due to rapid heating	Case Carburized Inner Ring - Reduces risk of inner ring crack due to thermal stresses
Uniform paper thickness	Bearings with controlled runout for higher running accuracy
Smearing damage due to roller skidding in high speed and light load	HCR (Tungsten carbide) Coated Bearings for significantly reduced smearing damage
High temperature	C4 Clearance Spherical Bearings to compensate for thermal expansion

NBC Solutions for Auxiliary Equipment

Auxiliary equipment is an integral part of the industry as several devices rely on it to operate and control the systems that deliver the desired output. Therefore, auxiliary equipment's maintenance and proper functioning become as crucial as that of the primary equipment. NBC provides bearings that can meet harsh conditions and challenges present in the case of secondary equipment, prevent any potential damage, cuts down the amount of energy consumption, and ensures continuous deliverability.



Gearbox is an essential piece of equipment, and any breakdown would lead to serious implications. Therefore, the main challenge for the bearing is to match the high-reliability demand of the equipment.

Bearings used:

- Tapered Roller Bearings
- Spherical Roller Bearing
- Cylindrical Roller Bearings
- Deep Groove Ball Bearing

NBC Benefits:

- Reduced friction and heat generation
- Better lubrication due to enhanced finishes
- Compact bearing designs



As pumps are exposed to heavy varying loads, it becomes imperative that bearings used shall sustain the stresses generated by these loads for reliable operation.

Bearings used:

- Deep Groove Ball Bearing
- Angular Contact Ball Bearing
- Tapered Roller Bearing

NBC Benefits:

- Reduced friction
- Reduced noise and vibration
- Less heat generation

Fans/blowers



The presence of contamination and unbalanced forces coupled with the problem of high speed and light load requires highly engineered bearings to meet reliability expectations.

Bearings used:

- Spherical Roller Bearing
- Self-aligning Ball Bearing
- Roller Housed Unit
- Deep Groove Ball Bearing

NBC Benefits:

- Enhanced bearing life
- Low operating temperature
- Low maintenance

Motor



In the case of motors, it is important that the bearings ensure reliable, continuous smooth, and quiet rotation.

Bearings used:

- Deep Groove Ball Bearing
- Angular Contact Ball Bearing
- Tapered Roller Bearing

NBC Benefits:

- Low noise
- Low vibration
- Current insulation
- Longer operating life

Modern paper machines use approximately 3000 bearings, and a high proportion of the bearings used are Spherical Roller Bearings. SRB is specially designed for the most demanding industrial applications and performs well when there are continuous shaft deflections and heavy loads. A long operating life becomes challenging with a bearing that must withstand high temperature, contamination, increased speed, and overloading. However, with the suitable material, innovative technology, and design, NBC has added some beneficial features to Spherical Roller Bearing that will prove to be performance enhancers.

NBC Spherical Roller Bearings for the pulp and paper industry

Being one of the dominant players in bearing manufacturing, NBC ensures that our Spherical Roller Bearings:

- Withstand high-temperature conditions
- Have enhanced performance and uptime
- Incur lower operating cost
- Have long duty cycles
- Engineered to have a robust design to increase reliability



The characteristic of the cages influences the performance and reliability of a bearing. Therefore, the choice of material becomes particularly important when selecting the right cage.

NBC offers spherical roller bearings in steel and brass cage designs across all ranges to suit different application needs that increase reliability and ensure maximum productivity.

**STEEL CAGE
BEARING**



**BRASS CAGE
BEARING**

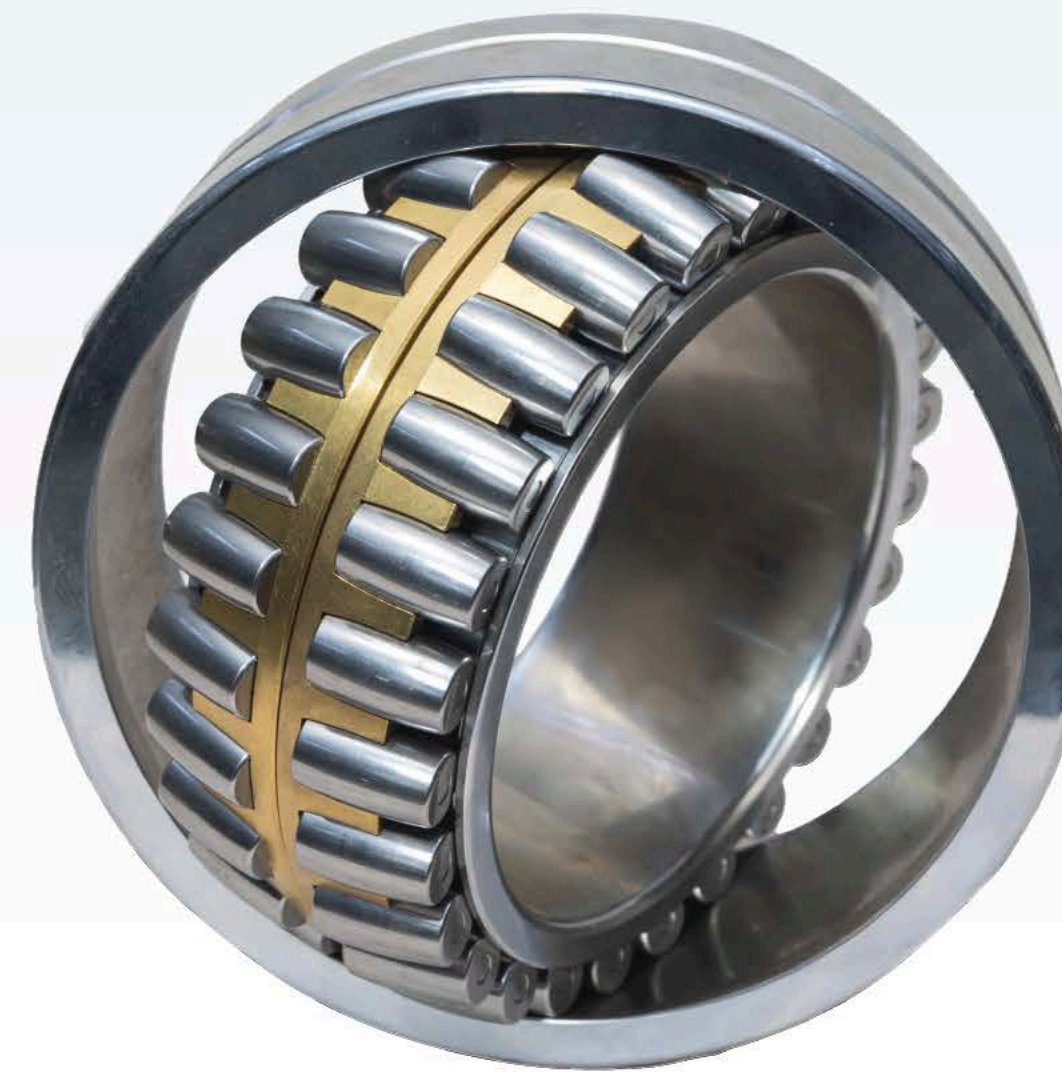

Size range	30-2000 mm OD
Variants	Straight bore, Tapered bore (1:12, 1:30)
Cage	Brass, Steel
Clearances	C2, CN, C3, C4, C5

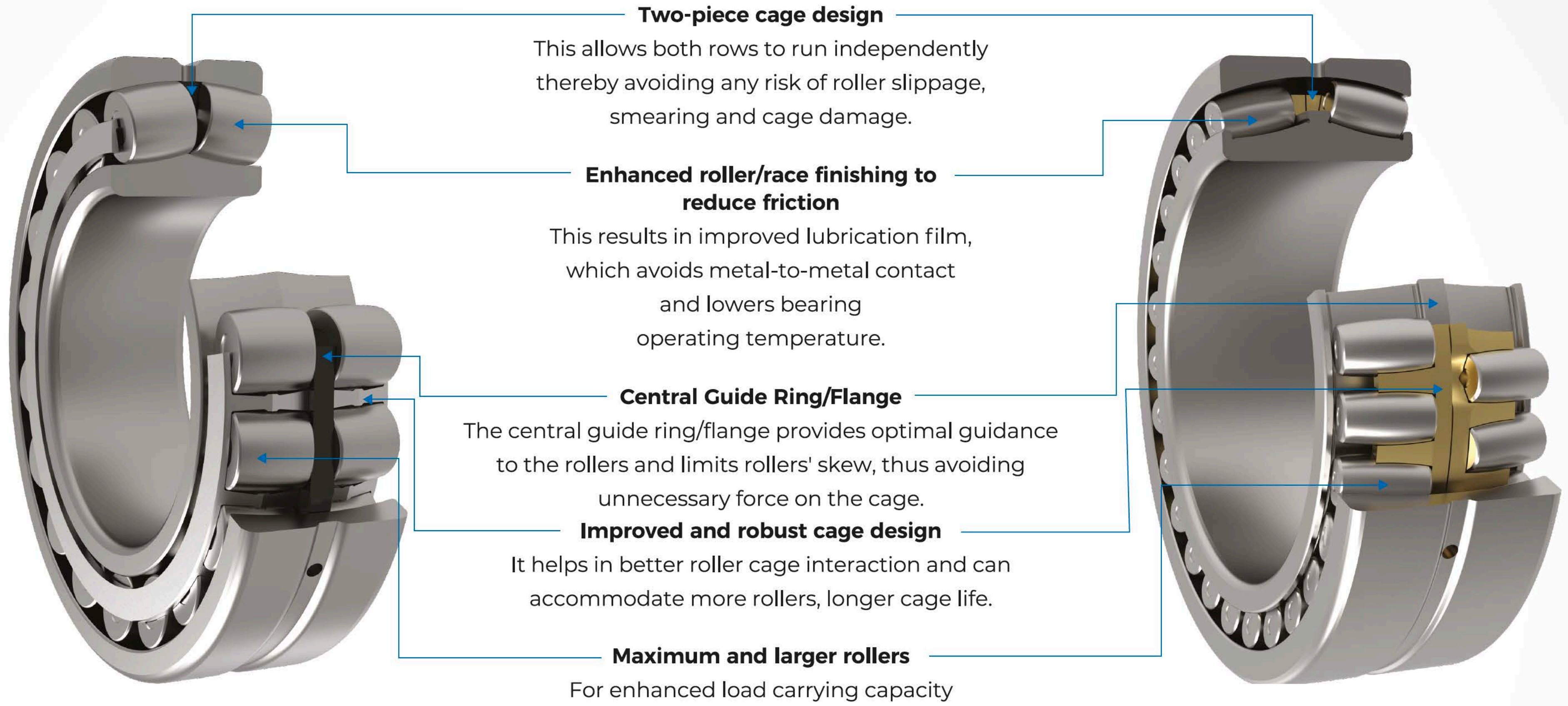

STEEL CAGE BEARING

- Surface hardened and lightweight cage design
- Suitable for high-speed applications
- Gives adequate performance for majority of applications

BRASS CAGE BEARING

- Brass cage bearings can deliver extra durability in extreme operating conditions
- Better performance in shock load applications
- Suitable for high centrifugal loading
- Better performance in reversing applications

When it comes to a bearing, the one-size-fits-all approach can result in premature bearing failure, costly downtime, production loss, etc. Since different industry needs different solutions, NBC Bearings has created an exclusive range of bearings as unique on-demand solutions that suit the requirement and challenges of the paper industry.

The surrounding conditions and environmental factors are taken into consideration in the development process of these bearings. The objective is to ensure that the bearing can sustain the harsh environment and match the industry's expectations.

Innovative Bearing solutions for high-performance

The technology imparts specific properties to the bearings that provide the following advantages over the conventional bearings:

- Long life in a corrosive and abrasive environment
- High operating temperature
- Better Ability to handle shock loads and stresses
- Better performance in marginal lubrication
- No/Low maintenance
- Higher operational reliability
- No re-lubrication needed
- High-speed operation



HCR- WEAR RESISTANT BEARINGS



Wear resistance coating on rolling element helps to avoid metal to metal contact in low film thickness and protects against adhesive and abrasive wear.

Features

Optimized coating with metal-containing amorphous carbon with a multilamellar structure

No columnar structure provides high adhesion strength

High dimensional accuracies

Benefits

- Low coefficient of friction even in dry condition - resistant to adhesive wear and micro pitting
- Enhanced fatigue life in insufficient lubrication condition
- Debris tolerance - removes dents created in the contaminated application

HCP- CORROSION RESISTANT BEARINGS



HCP bearing consists of a Hard chrome plating. It is an electroplating process wherein a thin layer of chromium is deposited by dipping the bearing into a chromic acid solution.

Features

Corrosion resistance

Low coefficient of friction

Higher Hardness (65-70 HRC)

Benefits

- Provides corrosion and wear protection in moisture and contaminated environment
- Extends the bearing lifespan

INSULATED BALL BEARINGS



Electrical insulation coating prevents electrical pitting in the bearings and improves bearing life in motor application.

Features

Aluminium oxide coating using plasma spraying technology

Current insulation

High thermal stability

Benefits

- Extending bearing service life by avoiding damage caused by electric current flow
- Higher operational reliability of electrical machinery

HIGH TEMPERATURE BEARINGS



NBC has developed unique heat treatment solutions for high temperature applications to provide superior dimensional stability for operating temperatures as high as 250°C.

Features

Special heat treatment

Excellent performance under hot environments

Benefits

- Dimensional stability at high temperatures
- Enhanced bearing service life at elevated temperatures

OIL IMPREGNATED BEARINGS



Oil impregnated bearings composed of 70-80% of lubricating synthetic oil. Oil is moulded and solidified with polymer to form a casing which acts as a lubricant reservoir throughout bearing's life.

Features

Improved lubrication with consistent lubricant supply

Superior lubricant: Synthetic oil

Excellent performance in water and dusty environment

Environment-friendly molding process

Benefits

- Long life and maintenance-free
- Higher operational reliability
- No re-lubrication needed
- No lubricant washout issue

SEALED SPHERICAL ROLLER BEARINGS



Sealed Spherical Roller bearings are like conventional spherical roller bearing in design and features, however for extra protection of bearing and lubricant from any external agents it has contact seals in the recesses of the outer ring.

Features

Effective and high-performance contact seals

Different seal materials to suit different operating temperatures

Benefits

- Reduced lubricant consumption
- Lower operating and maintenance costs
- Excellent protection against water splashes and contamination

HYBRID BALL BEARINGS



Hybrid bearing also known as anti-friction ball bearing consists of rolling element made of Silicon nitride in place of steel. Silicon nitride rolling elements perform exceptionally well in high-speed operating conditions.

Features

Lower friction

Reduced weight

Current insulation

Higher hardness

Benefits

- High speed capability
- Less wear under slippage
- Extended bearing service life
- Higher operational reliability

CASE CARBURISED BEARINGS

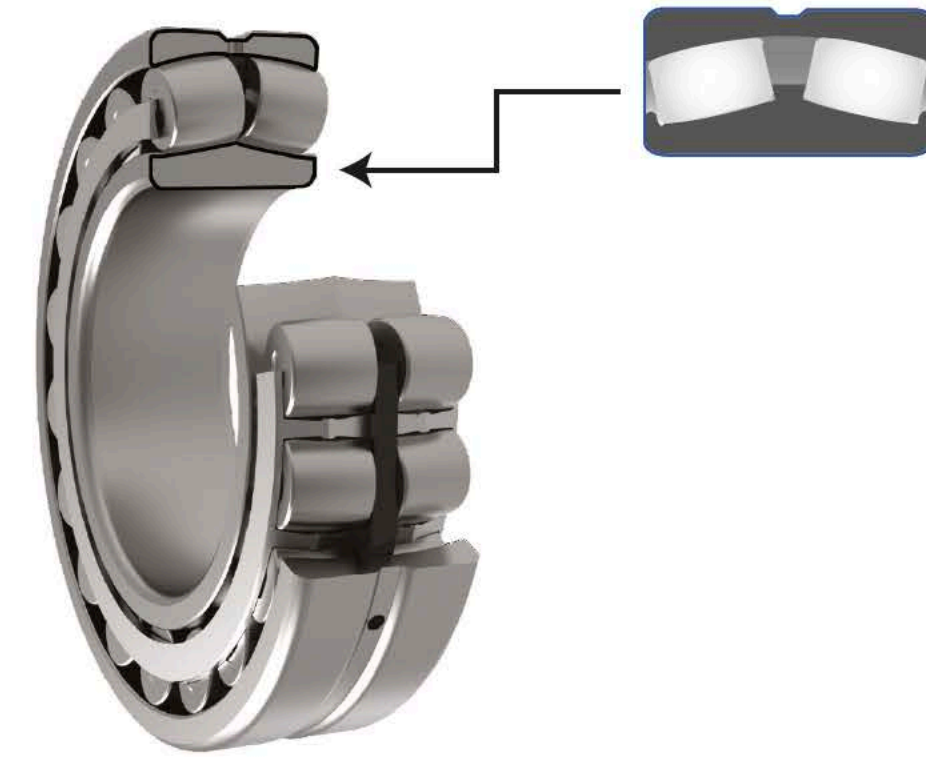

Case carburized bearings have a tough ductile core and a hard wear-resistant outer surface.

Features

Made of ultra clean low carbon steel

Ductile core helps enduring heavy shock loads

Compressive residual surface stresses

Benefits

- Reduced possibility of catastrophic damage due to surface cracks
- Better performance in boundary lubrication condition
- Ability to handle/manage some level of debris
- Sustains higher level of hoop stress

NBC Technical Consultation and Services: Condition Based Monitoring

NBC provides intelligent solutions for Condition Monitoring in order to improve the reliability of your assets.

Our expertise in various streams of Condition Monitoring helps industries maintain their machinery failure-free.

With a result-oriented approach towards avoiding machinery failure, the scope of CMS largely consists of Vibration Analysis and Lube Oil Analysis.



Our offerings

- **Vibration monitoring & analysis**
- **Bearing condition monitoring**
- **In-situ dynamic balancing**
- **Laser shaft alignment**
- **Thermography**
- **Annual maintenance contract / On-call service**

Other products from NBC

Since the challenges faced by industry are many, NBC offers a diverse range of exceptional bearings. NBC bearings are available in sizes from 06 mm bore to 2000 mm outer diameter.

- Deep Groove
- Gen - 1
- Gen - 3
- Angular Contact

Ball Bearings



Needle Bearings

- Single Row
- Double Row
- Four Row
- Unitised Tapered Roller Bearing
- Cartridge Tapered Roller Bearing (Railways)

Tapered Roller Bearings



Thrust Bearings

- Ball thrust
- Roller thrust

- Single Row
- Double Row
- Four Row
- Cylindrical Bearing Unit (CBU)

Cylindrical Roller Bearings



Pillow Block Bearings

- UCP
- UCF
- UCT

- Roller
- Plain

Spherical Bearings



Special Products & Technology

- Oil Impregnated Polymer Lubricated
- EMB Series High Speed (EV application)
- SIB Series Sensor Integrated
- Bearing with Conductive Wire
- TRB Hub Unit
- Low Torque TRB
- Pre-set Hub
- Insuohm Series (Insulated)
- Ceramic Rolling Element (Hybrid)
- TRB Matched Set
- Black Oxide Treatment
- HCR Series

* Products with special features like high temperature application, special heat treatment, coated roller/races and cage options are also available across product range.

NBC milestones

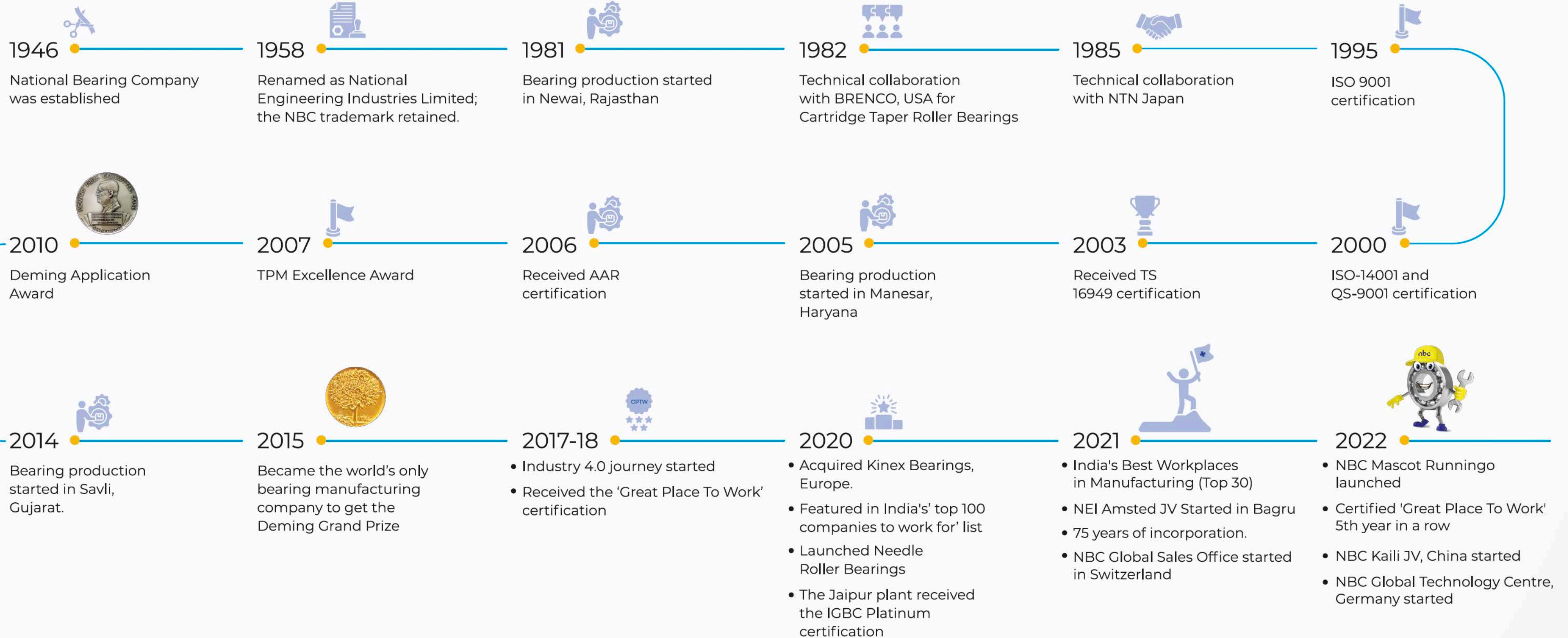

Our global reach

The NBC Bearings: Product, Technology & Services

NBC provides a wide range of bearings and associated service solutions to diverse industries such as Industrial, Automotive, Railways, and Aerospace. As a company that has been established for over 75 years, NBC Bearings has an international presence with offices and R&D centers across the globe.

For us, engineering goes beyond manufacturing; it is the fusion of Product, Technology, and Services that make us different and the most preferred choice of our customers worldwide.

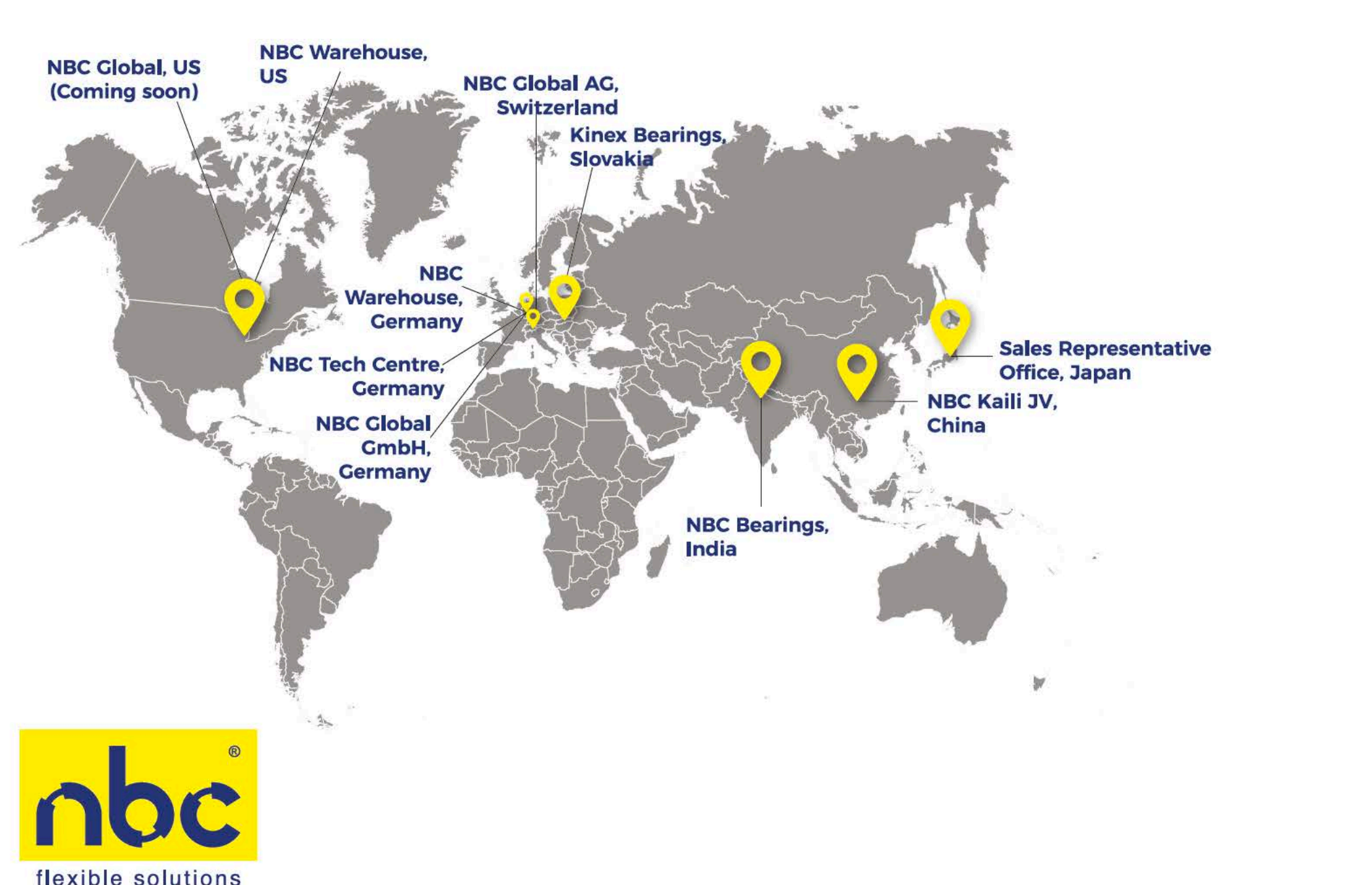

National Engineering Industries Ltd

Khatipura Road, Jaipur, Rajasthan, India 302 006

T: +91 141 2223 221 | F: +91 141 2222 259 | Toll free: 1800 3000 6222 | E: neilsales@nbcbearings.in

Follow us on: /nbcbearings | www.nbcbearings.com

